



En Chile: **Versol Ltda.**

www.versol.cl versol@versol.cl

Sopladores – Difusores de Aire – Bombas y Centrales de Vacío - Transporte Neumático
Válvulas Rotativas – Aspiradoras de Grano - Tubería de Bajada – Imanes – Tratamiento
Aguas Servidas y Riles - Té de Compost - Repuestos de Molinería – Equipos Agroindustria
Montajes Industriales Servicio Técnico de Sopladores y Bombas de Vacío.

Los Manzanos # 2568 - Huertos de La Pintana – La Pintana - Santiago - Chile – Tel. (56-2)27805528 – 27805530

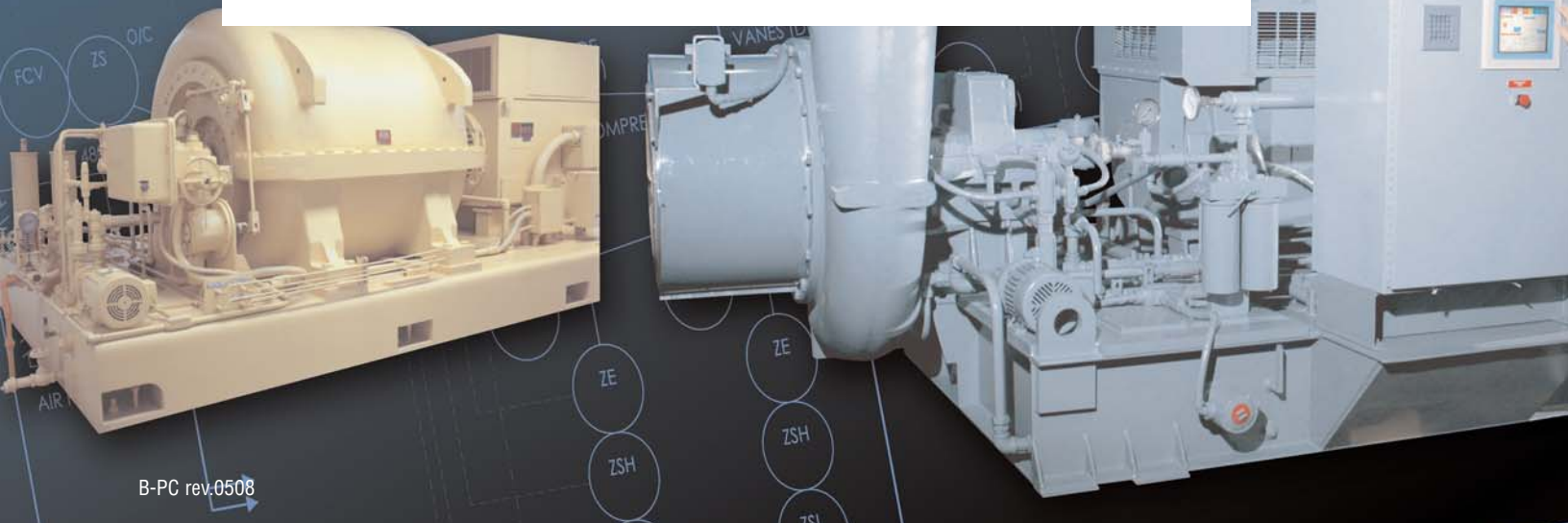

Dresser Roots

Dresser, Inc. is the longest continuously-run manufacturer of rotary positive displacement blowers in the United States. In 1854, Francis and Philander Roots, woolen mill owners in Connersville, Indiana, happened upon the principle that drives the rotary positive displacement concept.

Francis and Philander's attempts to improve efficiency in their mill's power system failed as the wooden lobed water wheel warped and jammed when put to use. In the course of investigating the problem on dry land, one of the brothers turned a shaft and rotated the pair of impellers. The impellers produced a large wind force blowing off his brother's hat. At that point, the brothers decided that they had a better blower than water wheel. Thus, the ROOTS™ blower concept and Roots Blower Company was created in their hometown of Connersville, Indiana, USA.

The rotary blower, invented around the same time as the telegraph and steam engine, has withstood the test of time as the other inventions have fallen along the wayside. During the early years, the units proved reliable as low-pressure air sources for everything from blacksmith forges, to mine ventilation, to powering the first New York City subway.

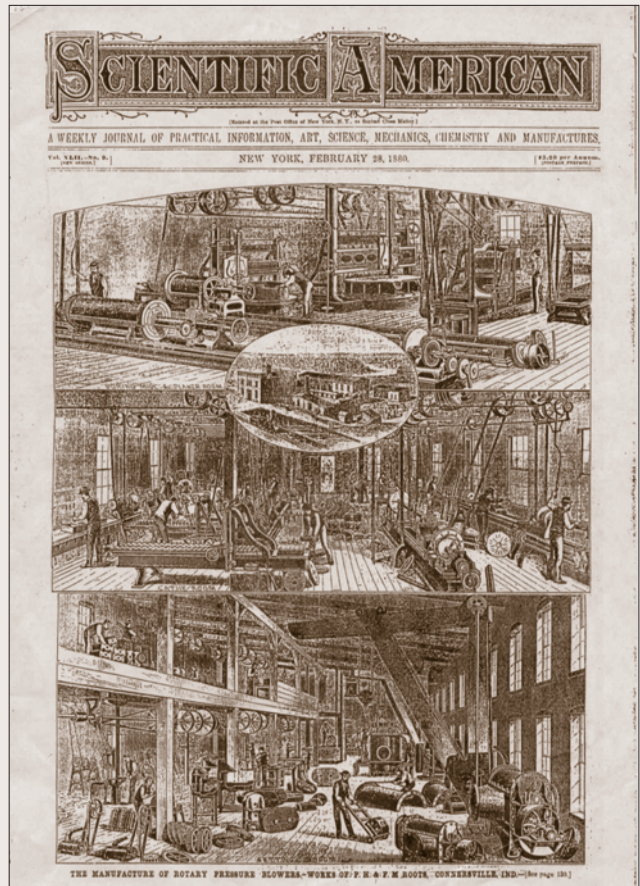

February 28, 1880 issue of Scientific American featured, as its cover story, "The Manufacture of Rotary Pressure Blowers - Works of P. H. & F. M. Roots, Connersville, Ind."

The original ROOTS blower™

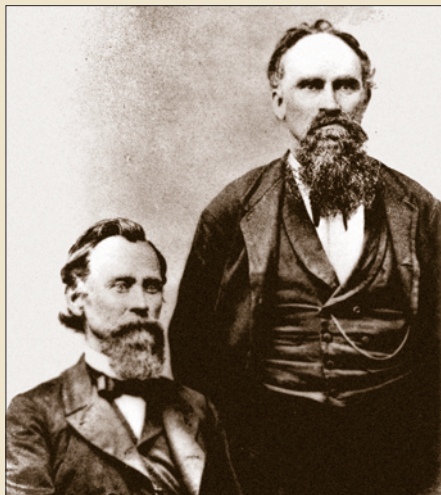

Francis and Philander Roots

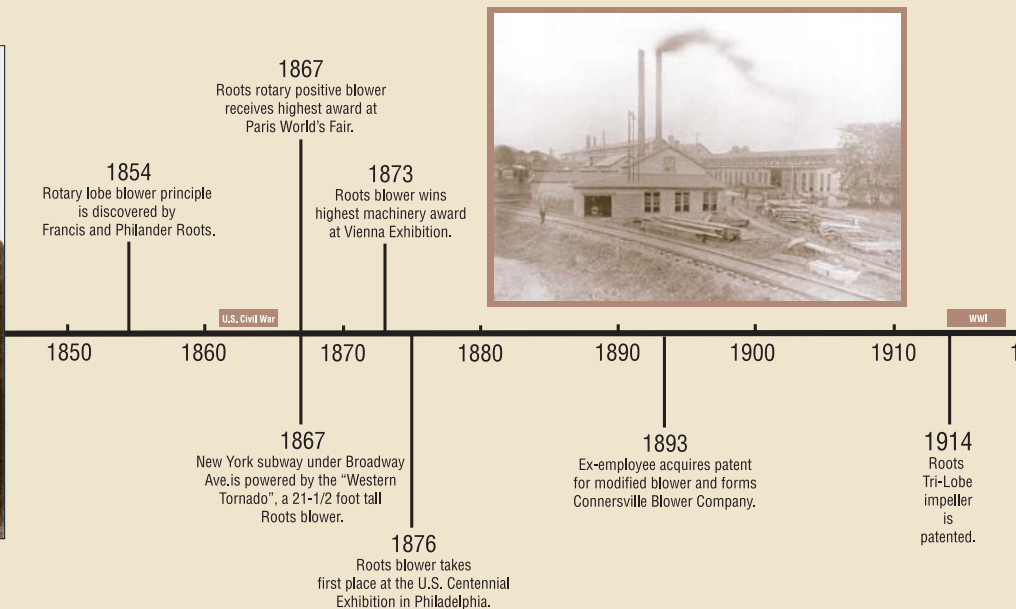

In 1893, an engineer broke from the Roots Blower Company and started the Connersville Blower Company. In the early 1900s Roots Blower Company invented a three-lobe blower to reduce pulses in the air flow. This engineering contribution would have its greatest impact nearly a century later as tri-lobe blowers were adopted for their quieter operation and reduced pulse.

The Roots Blower Company and the Connersville Blower Company continued in Connersville until 1931. At that time, the International Derrick and Equipment Company (IDECO) purchased both firms and created the Roots-Connersville Blower Company.

During 1931, Roots began to produce centrifugal compressors. Today, Roots manufactures integral-g geared, and pedestal-mounted, overhung, single-stage centrifugal compressors, as well as horizontally-split, multi-stage centrifugal compressors.

During WW II, Roots supplied Navy submarines and large surface craft with a special screw compressor used for ballast blowing.

In 1944, Dresser Industries, Inc. acquired Roots to expand its range of services for the gas and oil industries.

In 1990 Roots acquired Peabody Holmes and its plant in Huddersfield, England. The plant was founded in 1850 as W.C. Holmes Ltd. and began manufacturing rotary positive displacement air blowers in 1927. The Roots Huddersfield Operation handled European sales and manufacturing. In 2007 the operation moved to Skelmersdale in Lancashire.

During 1998, Dresser Industries merged with the Halliburton Company. In 1999, the Roots and DMD Division of Dresser Equipment Group, Inc. combined and in 2000 joined with the Instrument Division to form Dresser Measurement. During 2001, Dresser Equipment Group separated from Halliburton through a management buy-out to form Dresser, Inc.

In 2007 Roots acquired ESCOR Controls and integrated its water and wastewater controls expertise into the company's offerings and expanded the scope of the IntelliView® control systems.

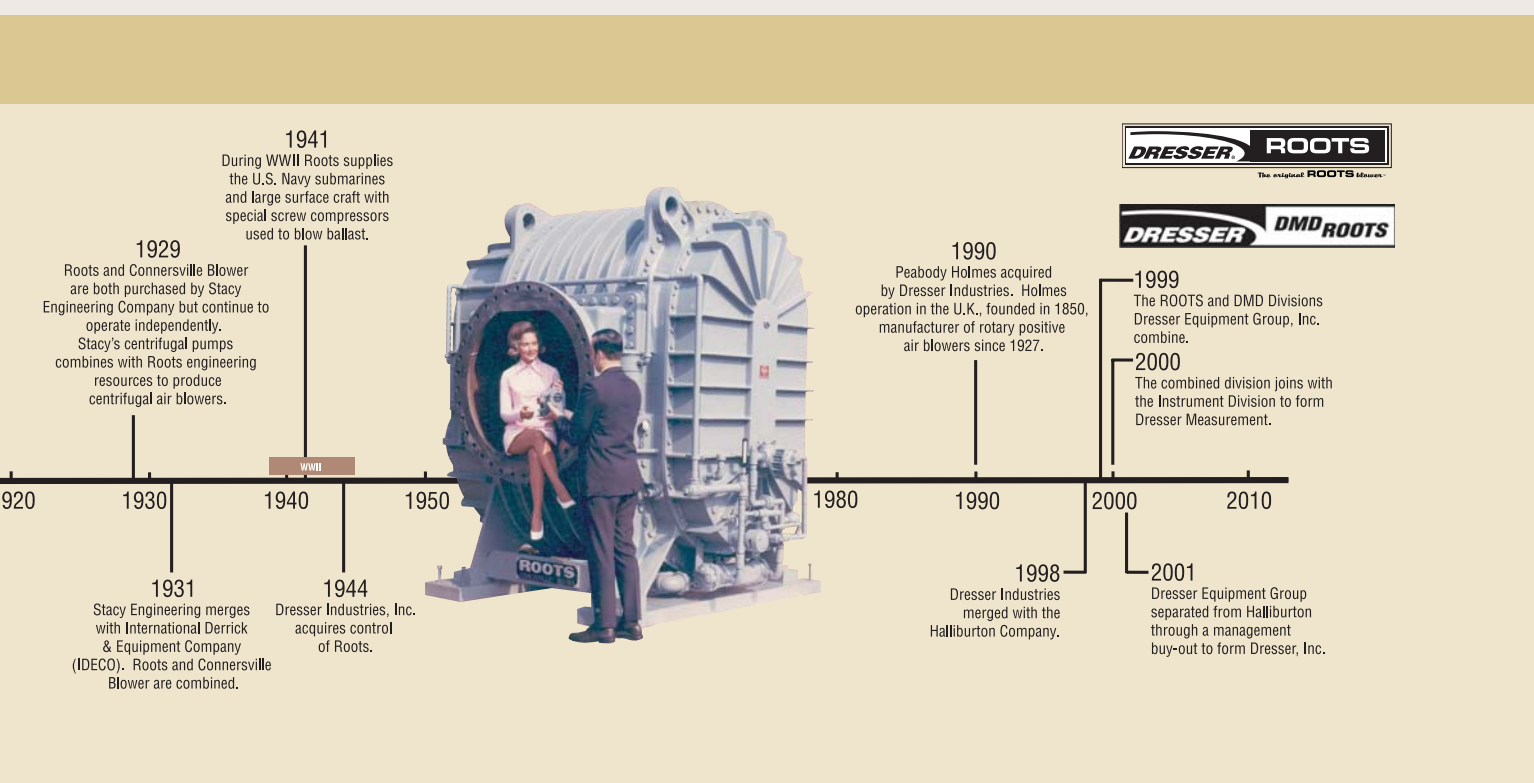

En Chile:

www.versol.cl

versol@versol.cl



Universal RAI® Blower

Universal RAI® Blower

Heavy-duty, bi-lobe rotary blowers in a compact, sturdy design engineered for continuous use with maximum reliability.

- Very cost effective design
- 2" (5.08 cm) thru 7" (17.78 cm) gear diameter
- Pressures to 15 psig (1034 mbar)
- Vacuums to 16" Hg (542 mbar)
- Flows to 2370 cfm (4026 m³/hr)



Universal RAI® DSL Blower

Universal RAI® DSL Blower

This model features dual splash lubrication on both the gear end and drive end.

- Sight glasses for accurate oil level

Universal RAI-G™ Blower

This model features a 1/8" (0.3137 cm) NPT purge port for buffer gas application as required, and mechanical seals to virtually eliminate leakage.

- 3" (7.62 cm) thru 6" (15.24 cm) gear diameter



Universal RAI-J™ Blower

Universal RAI-J™ Blower

Incorporates ROOTS™ WHISPAIR™ technology to reduce noise levels 3-5 dBA.

- 3" (7.62 cm) thru 5" (12.7 cm) gear diameter

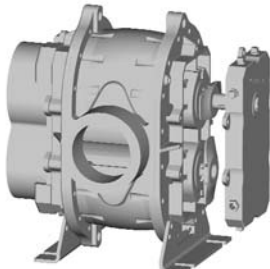

Universal RAI-J™ DSL Blower

Universal RAI-J™ DSL Blower

DSL features are incorporated into the Universal RAI-J™ model for longest life and quietest performance.

RAM-J Blower

Incorporates ROOTS™ WHISPAIR™ technology to reduce noise levels.

- Pressure to 18 psig (1240 mbar)
- Vacuum to 16" Hg (542 mbar)
- Flows 100 to 3500 cfm (170 to 5947 m³/hr)



RAM® Blower

RAM-GJ Blower

Standard gas blowers suitable for both vacuum and pressure service.



RAM® VJ Blower

RAM-VJ Blower

RAM™ WHISPAIR™ units are available with an inlet spray nozzle and seal water flow meter for water injection. This feature cools the vacuum unit to enable it to reach deeper vacuum.

- Vacuum to 24" Hg (813 mbar)
- Flows 180 to 2431 cfm (306 to 4130 m³/hr)



RAM-DPJ Blower

RAM-DPJ Blower

This RAM™ WHISPAIR™, dry, high-pressure blower features an exclusive discharge jet plenum to allow externally cooled gas to flow into the casing and the WHISPAIR™ jets control pressure equalization.

- Pressure to 30 psig (2068 mbar)
- Flows to 545 cfm (926 m³/hr)



RAM DVJ Blower

RAM-DVJ Blower

This dry exhauster features an exclusive jet plenum designed to allow cool, atmospheric air to flow into the casing. This design allows continuous operation at levels to blank-off with a single stage unit.

- 2" (5.08 cm), 4" (10.16 cm) and 6" (15.24 cm) gear diameter units
- Vacuum to 27" Hg (914 mbar)
- Flows 47 to 2002 cfm (80 to 3401 m³/hr)

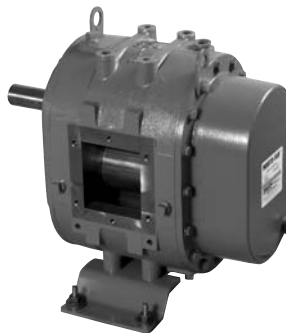

Roots-Flo® Blower

ROOTS-FLO® Blower

This heavy duty rotary unit is a compact design engineered for reliable pneumatic conveying of grain and similar products.

- 4" (10.16 cm) gear size only
- Vacuums to 16" Hg (542 mbar)
- Pressure to 15 psig (1034 mbar)
- Flows 133 to 1175 cfm (226 to 1996 m³/hr)



WHISPAIR™ Max Blower

2500 WHISPAIR™ Max Blower Series

This rotary positive WHISPAIR™ blower reduces noise and power loss by its unique flange design.

- Low noise level
- Less operating power required
- Detachable mounting feet permit in-field adaptability to vertical or horizontal installation

RCS 800 Blower

Piston rings reduce air leakage while lip-type oil seals prevent lubricant from entering the air chamber.

- Pressures 1 thru 18 psig (69 t hr 1241 mbar)
- Vacuums to 16" Hg (542 mbar)
- Flows 935 to 5200 cfm (1589 to 8835 m³/hr)



RCS Blower

RCS-J Blower

Incorporates ROOTS™ WHISPAIR™ technology to reduce noise levels.

RCS-VJ Blower

RCS WHISPAIR™ units are available with an inlet spray nozzle and seal water flow meter for water injection. This feature cools the vacuum unit to enable it to reach deeper vacuum.



RCS-J/RCS-VJ Blower

RBTM Blower

A rotary positive blower designed for use in truck-mounted applications, though it can be used in stationary applications with an electric motor. Available in three sizes offering a wide range of capabilities.

- Flows 942 to 4120 cfm (1600 to 7000 m³/hr)
- Pressure to 18 psig (1241 mbar)
- Vacuums from 15" Hg (500 mbar) to 27" Hg (900 mbar)



RBTM Blower

DVJ WHISPAIR™ Blower

These blowers have an exclusive WHISPAIR™ discharge jet plenum design which allows cool, atmospheric air to flow into the cylinder. This unique design permits continuous operation at vacuum levels to blank-off with a single stage unit, without water injection. The DVJ's cooling design eliminates the problems caused by high discharge temperatures at vacuum levels beyond 16" Hg.

- Gear diameters from 2.5" (6.3 cm) to 18" (45.72 cm)
- Flows from 170 to 16870 cfm (288 to 28662 m³/hr)
- Vacuums from 12" Hg (406 mbar) to 27" Hg (914 mbar)



DVJ Blower

TRI-NADO™ TM Blower

This unit's tri-lobe design results in high efficiency and reduces in-pipe pulsation and noise levels. Incorporates ROOTS™ WHISPAIR™ technology to further reduce noise levels.

- Flows to over 40,000 cfm (68,000 m³/hr)
- Single-stage vacuums to 18" Hg (610 mbar)
- Pressures to 18 psig (1240 mbar)



TRI-NADO™ TM Blower

RAM X™ Tri-Lobe Blower

The blowers feature ROOTS™ WHISPAIR™ discharge design which, when combined with our tri-lobe impellers, delivers quieter operation than conventional tri-lobe blowers.

- Flows to 5,456 cfm (9269 m³/hr)
- Vacuum to 16" Hg (541 mbar)
- Pressures to 15 psig (1034 mbar)



RAM X™ Tri-Lobe Blower



EASYAIR® X2 Factory Blower Package System

The EASYAIR® X2 Factory Blower Package System is an improved design based upon the popular EASYAIR® 8000 package. The EASYAIR® X2 system provides performance engineering in a standard package. It is produced for vacuum or pressure applications, enabling simple, on-site installation.

- Overall size is smaller than the EASYAIR® 8000 package and the side-to-side size accommodates more packages in a given area
- No electric fan hookup required as the fan is mounted on the blower shaft and driven mechanically resulting in longer life
- Patented automatic belt tension system optimizes performance and extends belt life
- Panel-mounted gauges (inlet filter differential, blower exhaust temperature and pressure) and external oil level view for easy monitoring
- Up to 22dBA free field noise attenuation with enclosure



En Chile:

www.versol.cl

versol@versol.cl

VJ/VJ2 Blower

Water injected, air or gas blower featuring 10" (25.4 cm) through 20" (50.8 cm) gear diameters. Features ROOTS™ WHISPAIR™ plenum with 3-5 dBA quieter operation.

Single stage

- Vacuum to 20" Hg (677 mbar)
- Flows 1,200 to 12,750 cfm (2039 to 21662 m³/hr)

Two stage

- Vacuum to 27" Hg (914 mbar)
- Flows 2,200 to 21,490 cfm (3738 to 36512 m³/hr)

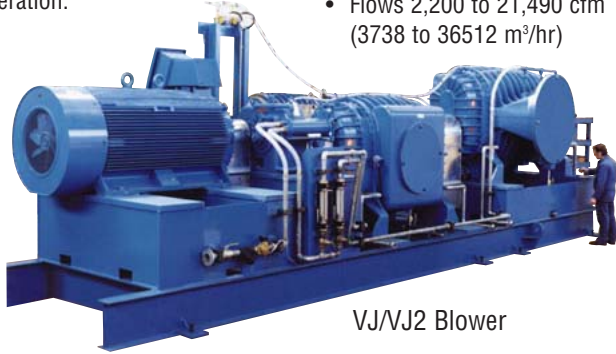

VJ/VJ2 Blower

RAS-J Blower

Air blower featuring 10" thru 20" (25.4 thru 50.8 cm) gear diameters. All units are available with DSL. Features a WHISPAIR™ plenum with 3-5 dBA quieter operation.

- Pressure to 35 psig (2413 mbar)
- Vacuum to 16" Hg (542 mbar)
- Flows 1320 to 28000 cfm (2243 to 47572 m³/hr)



RAS-J Blower

RAS-J Forty PSL Blower

Greater efficiency with the advantage of the WHISPAIR™ plenum in a 20" (50.5 cm) gear diameter size.

- Up to 82% more power handling capacity
- WHISPAIR™ plenum lowers noise up to 5 dBA



RAS-J Forty PSL Blower

RGS-J Blower

Heavy-duty gas blowers designed for continuous service. An exclusive wrap-around plenum and WHISPAIR™ jet eliminate rapid backflow of gas into the blower from the discharge area.

- Pressure to 35 psig (2413 mbar)
- Vacuum to 16" Hg (542 mbar)
- Flows 1320 to 28,000 cfm (2243 to 47572 m³/hr)

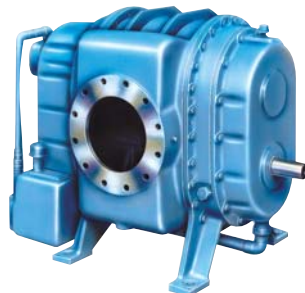

RGS-J Blower

RGS-HVB Blower

Designed for applications to the single digit micron range when used in series with a backing pump.

- Gross displacement to 31,920 cfm (54232 m³/hr)

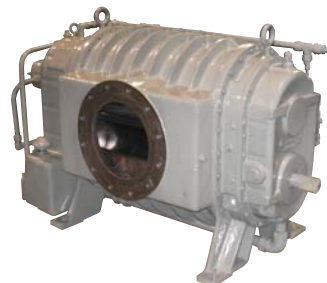

RGS-HVB Blower

Type OIB Centrifugal Compressor

This compressor feature a stiff shaft design which assures an operating speed well below the first critical speed of the shaft.

A wide range of stable operation is provided by these units with surge occurring at approximately 50% of design capacity. Use of adjustable inlet

guide vanes can extend this to 30% of design capacity or 70% turndown.

- Polytropic heads to 34,000 ft.
- Flows from 5000 to 250000 cfm (8495 to 424753 m³/hr)

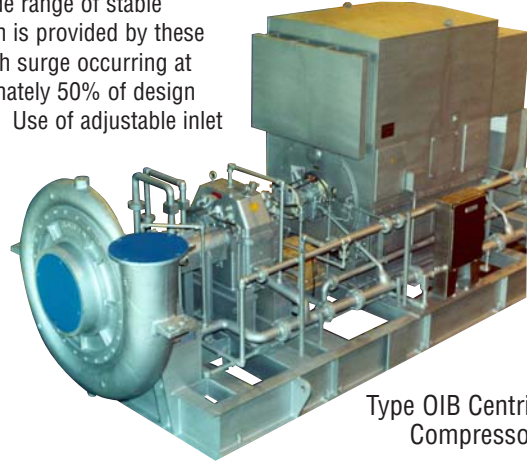

Type OIB Centrifugal Compressor

Type IGC Centrifugal Compressor

This compressor is suitable for use with a variety of constant speed or variable speed drivers. Local energy costs and your requirements will determine the most economical method of drive for your application.

Adjustable inlet guide vanes control the capacity with a minimum loss of efficiency, and also increase the stable operating range.

Adjustable diffuser vanes are available for certain applications where constant inlet temperature

exists and constant discharge pressure is desired.

- Polytropic heads to 50,000 ft.
- Flows to 60000 cfm (101949 m³/hr)



Type IGC Centrifugal Compressor

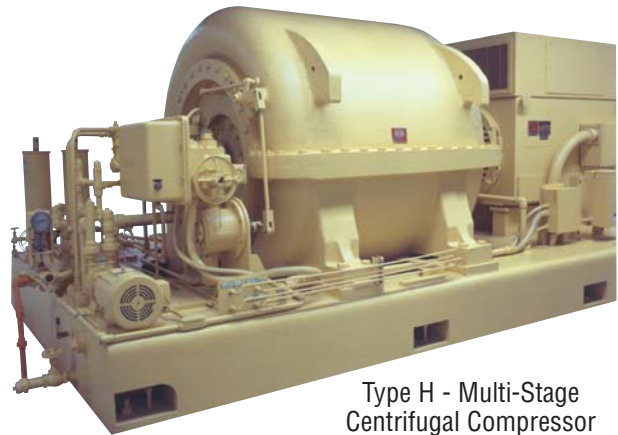

Type H - Multi-Stage Centrifugal Compressor

Type H - Multi-Stage Centrifugal Compressor

A choice of impeller materials provides efficient, reliable operation with a variety of process gases at varying temperatures, humidity levels and pressures. Horizontally-split casing compressors feature bearing housings that are flange mounted to the case. This design permits easy access for maintenance or bearing inspection.

- Polytropic heads to 90,000 ft.
- Flows from 9,000 to 125,000 cfm (15291 to 212376 m³/hr)

Controls

Roots – finest control technology is always available as integral system with ROOTS™ aeration blowers and solutions.

Wastewater OEMs – can take advantage of including our controls with their equipment for best system performance.

Revamp – extends aeration system life and optimizes performance by replacing obsolete controls with state-of-the-art standard or customized control systems and solutions to meet your needs.

Upgrades – reduce energy consumption and optimize performance of your aeration system by adding specialized controls - for example, DO and MOV. Retrofit systems are available for almost any combination of blowers and aeration processes.

Performance Service – features regular scheduled on-site service and equipment inspection, system tuning and optimization.

Application Engineering – includes site review and inspection for energy audits, data analysis, savings projections, recommendations, system and solution design.

Technology Options:

- IntelliView® Process Controller
- PLCs (various)
- Direct Flow Control
- Dissolved Oxygen (DO)
- Most Open Valve (MOV)
- Pressure Control
- Direct Valve Control
- Best Application Specific Control Algorithms

Revamp Services

Backed by 150 years of air and gas handling experience, Roots Revamp Services offers scalable standard and customized complete mechanical and control solutions to meet your changing system demands, including

- Roots on-site blower and aeration system performance audits.
- Performance guarantees:
 - Aeration & Controls
 - Target flows at target discharge pressures and at the expected power
 - Thorough on-site or factory testing
- Roots service staff offers for blowers and controls:
 - Removal, full system (re-) installation, testing, start-up, training and performance confirmation
- Annual/Quarterly services

Roots Revamp Services are scalable to provide the best fit to your requirements:

- Blower, controls and aeration system on-site audit by Roots team of experts
- Roots job-site equipment removal and return services
- Minimize plant disruption with service coordinated to your schedule
- Guaranteed performance:
 - Thorough on-site or factory testing
 - Controls and Aeration
- Roots proven design and controls programming
- Re-Installation and start-up services

Global Aftermarket Coverage

Roots maintenance and repair services provide professional methods and procedures that restore proper functionality and performance to each repaired unit. Access to Roots factory repair and service is available around the world, see the back cover for your nearest location. Service for small rotary blowers is available through our network of authorized distributor repair centers which can be searched on our website. All authorized repair centers use authentic ROOTS™ parts to assure warranty compliance.

Unmatched Experience

We have extensive experience in the repair and maintenance of all brands of vacuum blowers and exhausters, blowers, and centrifugal compressors. Our capabilities allow us to repair or remanufacture all of your equipment to original or higher specifications. Roots provides full service and repair on all brands.

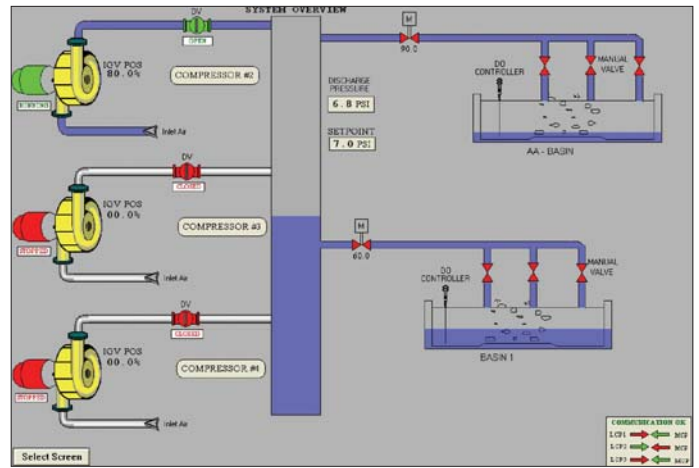

Roots' control solutions for your aeration process are state-of-the-art assuring your plant optimum Dissolved Oxygen (DO) with minimal energy consumption.

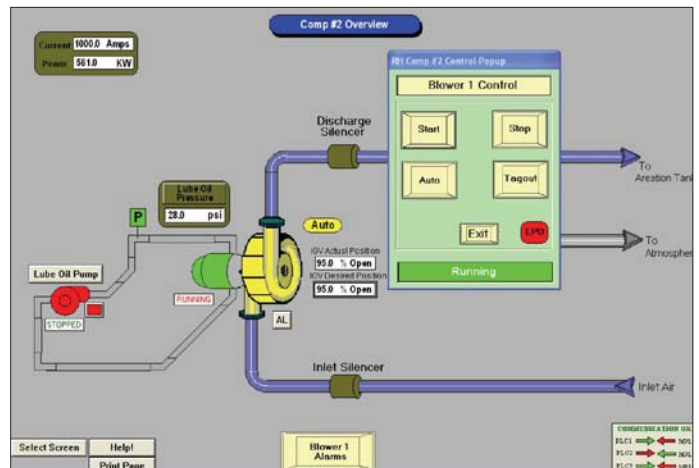

Reduce Power Costs

Your current aeration blower system may be the biggest single opportunity to reduce your power overhead.

When installed, your aeration blowers were matched for best efficiency at the original performance conditions. Times change, conditions change...

Roots Revamp Services looks at today's and projected future conditions to analyze and establish updated best performance requirements for the blowers and complete aeration control – for example a 10 psig blower running at 8 psig uses 6% more power than a blower designed for 8 psig.

Superior Field Services

- Full job-site troubleshooting services and capabilities
- State-of-the-art diagnostic tools delivered and utilized on-site for thorough diagnosis prior to removal
- 24-hour delivery for most parts and repair kits

Strongest Service and Repair Warranties in the Business

Roots backs all maintenance and repair work performed at Roots facilities or in the field.

- One year parts and workmanship including competitor's parts
- Competitive pricing
- ISO-9001 Certified-Houston, TX, & Connersville, IN

En Chile: www.versol.cl

versol@versol.cl

About Dresser, Inc.

Dresser, Inc. is a leader in providing highly engineered infrastructure products for the global energy industry. The company has leading positions in a broad portfolio of products including air and gas handling equipment, valves, actuators, meters, switches, regulators, piping products, natural gas-fueled engines, and retail fuel dispensers and associated retail point of sale systems. Leading brand names within the Dresser portfolio include

Dresser Roots™ blowers, compressors and controls, Wayne® retail fueling systems, Waukesha® natural gas-fired engines, Masoneilan® control valves, Mooney® regulators, Consolidated® pressure relief valves, and Roots® rotary gas meters. It has manufacturing and customer service facilities located strategically worldwide and a sales presence in more than 100 countries. The company's website can be accessed at www.dresser.com

Dresser Roots

En Chile: **Versol Ltda.**

www.versol.cl versol@versol.cl

Sopladores – Difusores de Aire – Bombas y Centrales de Vacío - Transporte Neumático
Válvulas Rotativas – Aspiradoras de Grano - Tubería de Bajada – Imanes – Tratamiento
Aguas Servidas y Riles - Té de Compost - Repuestos de Molinería – Equipos Agroindustria
Montajes Industriales Servicio Técnico de Sopladores y Bombas de Vacío.

Los Manzanos # 2568 - Huertos de La Pintana – La Pintana - Santiago - Chile – Tel.(56-2)27805528 – 27805530



www.dresser.com